

IRtec Rayomatic 14 Mk2

Compact with Remote Control Display Infrared Temperature Sensor



INFRARED THERMOMETERS

- ▶ Miniaturized Head M12x1
- ▶ IP65 Metal Case with Tilting Panel and SNAP-IN Fixing
- ▶ Ambient Working Head Temp. up to 180°C without Cooling
- ▶ Temperature Range up to 1000°C
- ▶ Up to 95:1 Optics
- ▶ Close Focus Lens 0.6mm Target
- ▶ Large LCD Display with 3 Colours Backlit for Easy Alarm Status ID
- ▶ Configurable Output mV, V, mA, Tc J/K or Relais Output
- ▶ Adjustable Emissivity, Response Time and Signal Processing with Built-In Programming Keys
- ▶ Easy Parameters Selection with Menu
- ▶ HS - High Speed Version 9 ms
- ▶ Password Protection on Setup
- ▶ "Black Box" Module for Events Recording with Real Time Clock
- ▶ Interface IRS232, RS485, USB, PROFIBUS with IRSetup Software
- ▶ Built-in Dual Relay Output Board

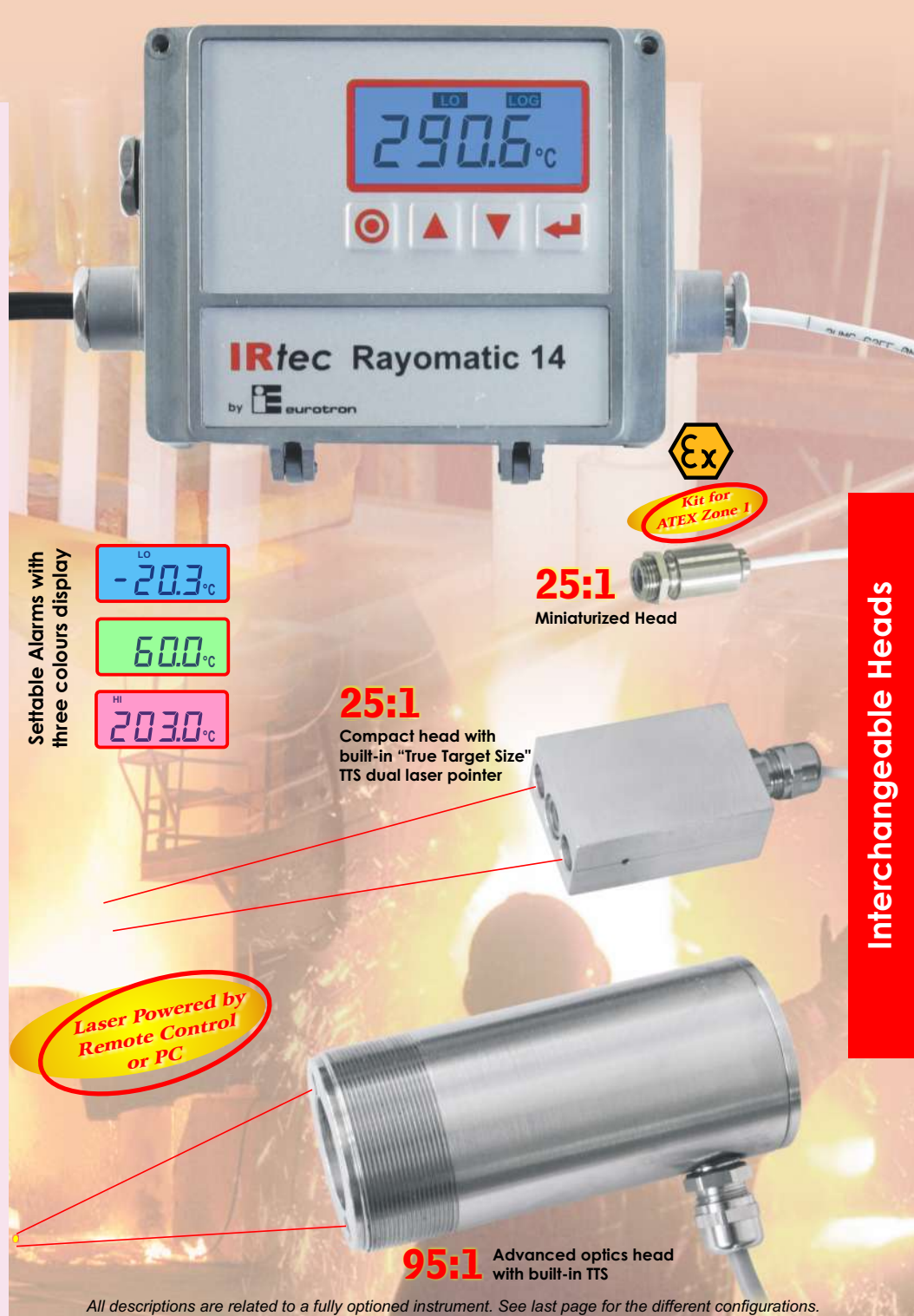

Introduction

As the infrared sensor Eurotron **IRtec Rayomatic 14** consists of two pieces (miniature sensing head with separate electronics) it can be easily installed in a variety of applications, especially if industrial environment requires space-saving installation. The stainless steel sensing head as well as the teflon-coated cable are standard equipment for ambient temperatures up to 180 °C. The labelling of each sensing head with the according calibrating code allows the exchange of head or electronic box without additional calibration. The electronic board of the **IRtec Rayomatic 14** is mounted inside a rugged die casting box. Various analogue outputs (0/4...20 mA, 0...10 V, J-type or K-type thermocouple) and optional digital interfaces (USB, RS232, RS485) are available. Easily accessible programming keys and a back-lit LCD display permits a Smart Panel-Operation to set and adjust essential parameters on-site.

Advanced Functions

The post processing supplies some functions to process data after the basic temperature calculation.

Advanced Peak/Valley Hold:

In the mode Advanced Peak/Valley Hold mode the **IRtec** unit waits for local peak/valley values. The signal must drop below the Threshold value to detect the next peak/valley (which must be above threshold). Furthermore, the Hysteresis causes to only accept a new peak/valley, if the signal descends/ascends by the value of the hysteresis.

Applications

Electronics

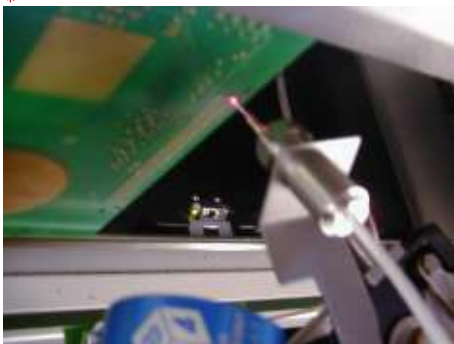

Rubber



Automation



Plastic



Laser Pinpointing

TTS - True Target Size

A dual laser pointer define at different distances the true target dimension. This unique and innovative system goes over the limits of the old crossed laser pointer based system. TTS guarantees the measuring of the true area diameter along all the optical path.

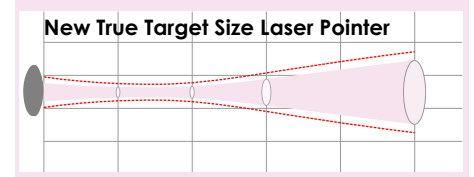

Remote Laser Pinpointing

By connecting the laser to the programming unit, the operator can remotely switch the laser on or off for easy thermometer sighting.

Adjustable Emissivity

The emissivity of the measured surface can be set in value or chosen from a typical preset materials table.

Software

BB260195

IR SETUP - Configuration Software

Compatible with WIN 95/98/2000/XP, the IRSetup software package provides for:

- easy sensor setup and remote controlling via USB or RS232 interface
- adjustment of signal processing functions



BB260196

LogMan - Datalogging Software

Compatible with WIN 98/2000/XP, the LogMan software package provides for:

- automatic data logging for analysis and documentation
- graphic display of temperature trends

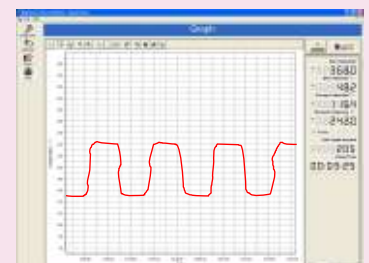

Dimensions

■ Programmable Alarms

High and Low level alarm can be set from the instrument or from PC. The alarm condition is displayed by the backlite color of the display (blue, green, and red) and the optional Relay output board.



■ RS232, RS485, USB or PROFIBUS

The optional communication facility allows to connect the instrument directly to a Personal Computer for settings and remote controlling. The most common industrial standards are available to include the instrument in the control system.

■ Event Log

The optional Event/Data Logging board, can store up to xxx measure or anomalous events (alarm status, overheating, etc.) complete with data and time. Data can be read from the instrument or downloaded to the PC.

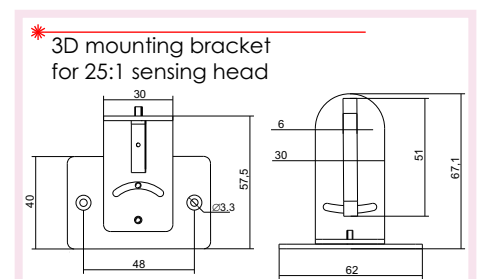
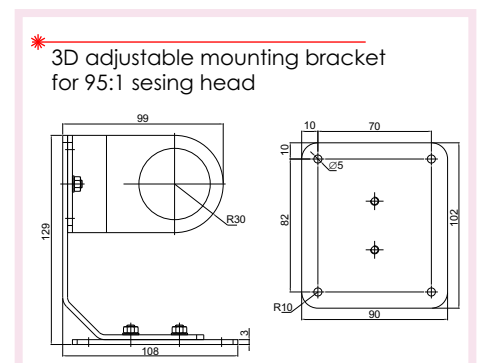
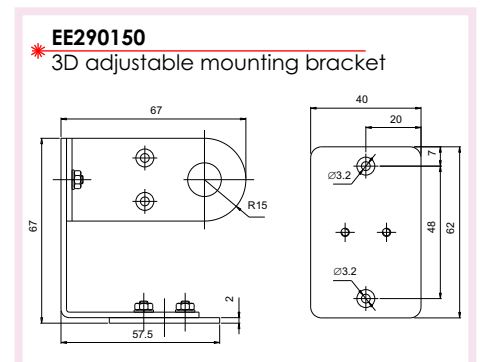
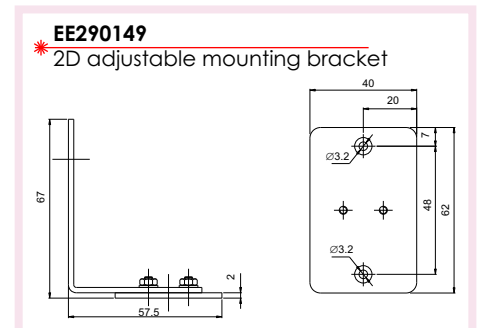
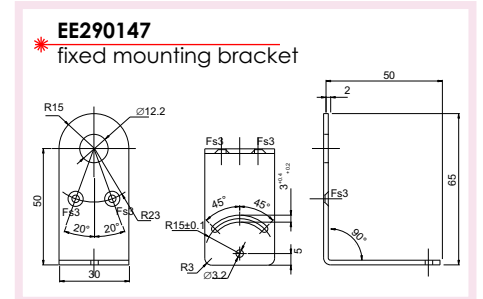
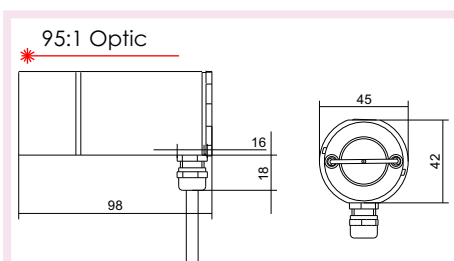
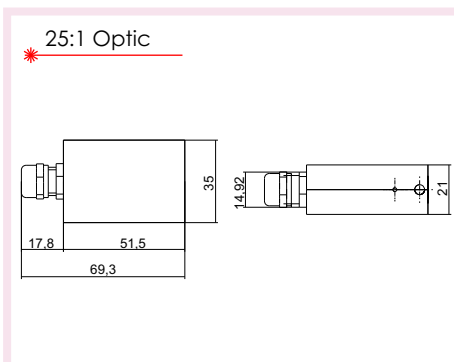
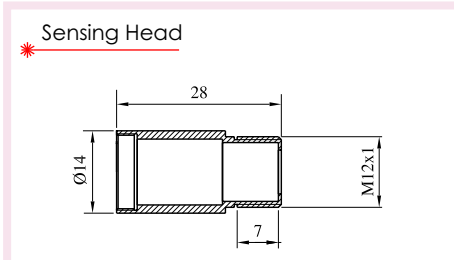
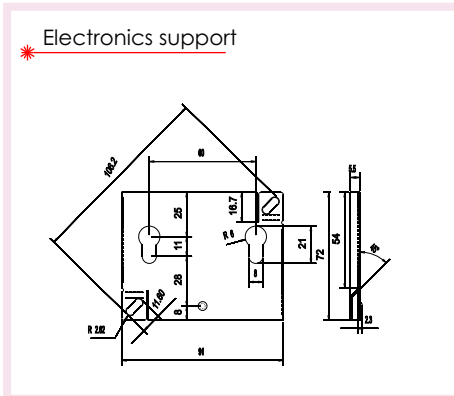
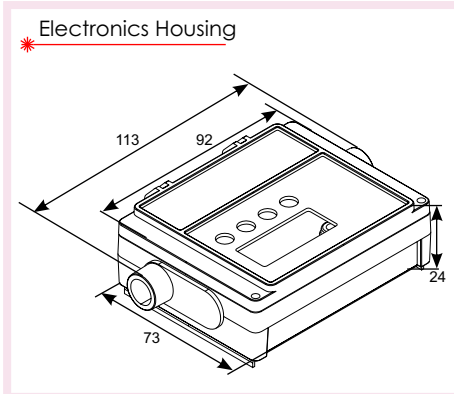

Fast Installation and Maintenance



SNAP-IN Fixing for Fast Mounting

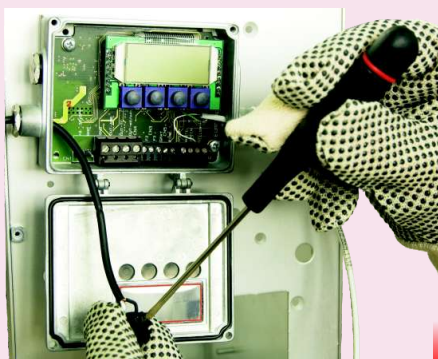

Tilting Panel for Easy Connection

Optics

Spot size calculated at 90% of energy

Specifications

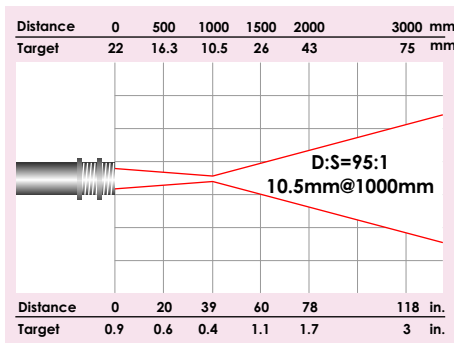
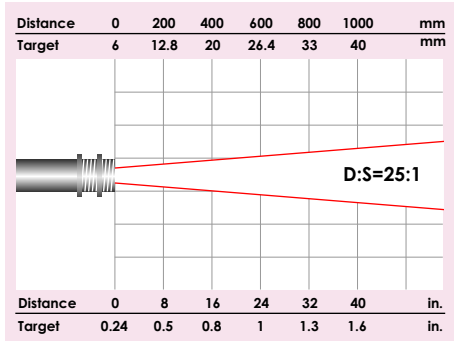
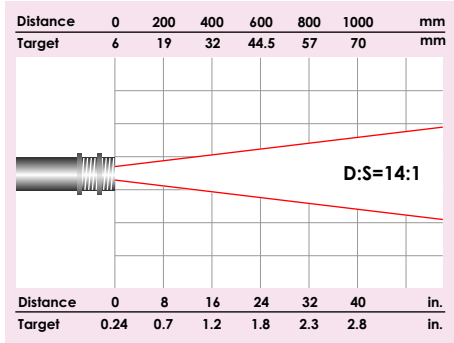
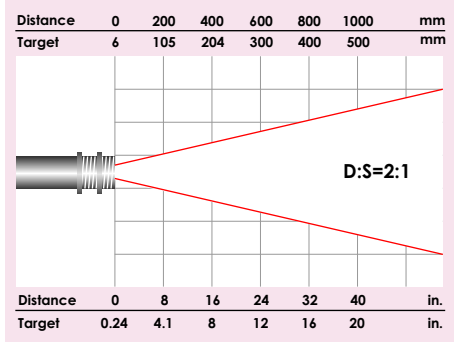

EE360158 - Close Focus lens

The optional CF-lens allows the measurement of small objects. The minimum spot size depends on the used sensing head:

2.5 mm@ 25 mm with 14:1-head
 0.6 mm@ 10 mm with 25:1-head

Spectral range: 8 to 14 μ m
Response time: 150 ms (95 %) - **HS:** 9ms (90%), 3 ms (50%), 20 ms analog output (90%) and 4 ms digital output (50%)
Accuracy: ± 1 % or ± 1 °C whichever is greater ($T > -20$ °C; ambient temperature $+23$ °C ± 5 °C)
Repeatability: $\pm 0,5$ % or $\pm 0,5$ °C whichever is greater
Temperature Coefficient: $\pm 0,05$ %/ K or $\pm 0,05$ K/ K whichever is greater
Signal processing: peak hold, valley hold, average
Emissivity: 0.100 to 1.100 (manually or digitally adjustable)
Transmissivity: 0.100 to 1.100 (manually or digitally adjustable)
Power supply: 8 VDC to 36 VDC
Current draw: max. 100 mA
Outputs/ analog:
Object temperature: 0 to 20 mA or 4 to 20 mA or 0 to 5 V or 0 to 10 V or thermocouple type J or K
Head temperature: 0 to 5 V or 0 to 10 V; 10 mV/ K or alarm output
Relais: 2 x 60 VDC/AC, 0,4 A; optically isolated (optional module)
Output impedances:
 mA max. loop resistance 500 Ω (at 8-36 VDC),
 mV min. 100 K Ω load impedance
 Thermocouple 20 Ω

Functional inputs F1 F3: software programmable for the following functions: external emissivity adjustment, ambient temperature compensation, trigger

Digital interface: USB, RS232, RS485 (optional modules)

Environmental rating: IP65 (NEMA-4)

Ambient temperature: Sensing heads: -20 to 180 °C (25:1 miniaturized head) / -20 to 120 °C (HS 14:1 and 2:1 heads) / -20 to 85°C (-20 to 50°C with laser on) for 25:1 TTS and 95:1 TTS heads - *Electronic box:* 0 to 65 °C

Storage temperature: Sensing head: -40 to 180 °C (120°C for HS, 14:1 and 2:1 heads) / -20 to 85°C (25:1 TTS and 95:1 TTS heads) - *Electronic box:* -40 to 85 °C

Vibration (sensor): IEC 68-2-6: 3G, 11-200 Hz, any axis

Shock (sensor): IEC 68-2-27: 50 G, 11 ms, any axis

Relative humidity: 10 to 95 %, non condensing

Dimensions: Sensing head: $\varnothing 28$ mm x 14 mm (M12x1) / 93,3 mm x 35 mm (25:1 TTS optic) / $\varnothing 45$ mm x 90 mm (M44 x 1,5) (95:1 TTS optic) - *Electronic box:* 89 mm x 70 mm x 30 mm

Weights: Sensing head: 40 g / 100 g (25:1 TTS optic) / 340 g (95:1 TTS)

Ordering Code

Code	Model																																												
1158	IRtec Rayomatic 14, head mounting nut and instruction manual.																																												
	<table border="1"> <thead> <tr> <th>Table A</th> <th>Optics</th> <th>Ranges</th> <th>Accessories</th> </tr> </thead> <tbody> <tr> <td>814-1</td> <td>Miniaturized 2:1</td> <td>-40 to 600°C</td> <td></td> </tr> <tr> <td>814-14</td> <td>Miniaturized 14:1</td> <td>-40 to 900°C</td> <td></td> </tr> <tr> <td>814-25</td> <td>Miniaturized 25:1</td> <td>-40 to 1000°C</td> <td></td> </tr> <tr> <td>814-25LS1</td> <td>25:1 TTS Dual Laser Pointer</td> <td>-40 to 1000°C</td> <td>3D mounting bracket</td> </tr> <tr> <td>814-25HS</td> <td>Miniaturized 25:1 HS (9 ms)</td> <td>-40 to 600°C</td> <td></td> </tr> <tr> <td>814-25LSHS</td> <td>25:1 LS HS (9 ms) TTS dual laser</td> <td>-40 to 600°C</td> <td>3D mounting bracket</td> </tr> <tr> <td>814-95LSHS</td> <td>95:1 LS HS (9 ms) TTS dual laser</td> <td>-40 to 600°C</td> <td>fixed mounting bracket</td> </tr> <tr> <td>814-95LS1</td> <td>95:1 TTS Dual Laser Pointer</td> <td>-40 to 1000°C</td> <td>fixed mounting bracket</td> </tr> <tr> <td>814-95LSCF</td> <td>Close Focus 0.9mm@85mm</td> <td>-40 to 1000°C</td> <td>fixed mounting bracket</td> </tr> <tr> <td>814-SP</td> <td>Special on request</td> <td></td> <td></td> </tr> </tbody> </table>	Table A	Optics	Ranges	Accessories	814-1	Miniaturized 2:1	-40 to 600°C		814-14	Miniaturized 14:1	-40 to 900°C		814-25	Miniaturized 25:1	-40 to 1000°C		814-25LS1	25:1 TTS Dual Laser Pointer	-40 to 1000°C	3D mounting bracket	814-25HS	Miniaturized 25:1 HS (9 ms)	-40 to 600°C		814-25LSHS	25:1 LS HS (9 ms) TTS dual laser	-40 to 600°C	3D mounting bracket	814-95LSHS	95:1 LS HS (9 ms) TTS dual laser	-40 to 600°C	fixed mounting bracket	814-95LS1	95:1 TTS Dual Laser Pointer	-40 to 1000°C	fixed mounting bracket	814-95LSCF	Close Focus 0.9mm@85mm	-40 to 1000°C	fixed mounting bracket	814-SP	Special on request		
Table A	Optics	Ranges	Accessories																																										
814-1	Miniaturized 2:1	-40 to 600°C																																											
814-14	Miniaturized 14:1	-40 to 900°C																																											
814-25	Miniaturized 25:1	-40 to 1000°C																																											
814-25LS1	25:1 TTS Dual Laser Pointer	-40 to 1000°C	3D mounting bracket																																										
814-25HS	Miniaturized 25:1 HS (9 ms)	-40 to 600°C																																											
814-25LSHS	25:1 LS HS (9 ms) TTS dual laser	-40 to 600°C	3D mounting bracket																																										
814-95LSHS	95:1 LS HS (9 ms) TTS dual laser	-40 to 600°C	fixed mounting bracket																																										
814-95LS1	95:1 TTS Dual Laser Pointer	-40 to 1000°C	fixed mounting bracket																																										
814-95LSCF	Close Focus 0.9mm@85mm	-40 to 1000°C	fixed mounting bracket																																										
814-SP	Special on request																																												
	<table border="1"> <thead> <tr> <th>Table B</th> <th>Head Cable length</th> </tr> </thead> <tbody> <tr> <td>1m</td> <td>1 mt</td> </tr> <tr> <td>3m</td> <td>3 mt</td> </tr> <tr> <td>8m</td> <td>8 mt</td> </tr> <tr> <td>15m</td> <td>15 mt</td> </tr> <tr> <td>Xm</td> <td>Special length on request</td> </tr> </tbody> </table>	Table B	Head Cable length	1m	1 mt	3m	3 mt	8m	8 mt	15m	15 mt	Xm	Special length on request																																
Table B	Head Cable length																																												
1m	1 mt																																												
3m	3 mt																																												
8m	8 mt																																												
15m	15 mt																																												
Xm	Special length on request																																												
	<table border="1"> <thead> <tr> <th>Table C</th> <th>Options</th> </tr> </thead> <tbody> <tr> <td>NO</td> <td>None</td> </tr> <tr> <td>RS232</td> <td>RS232 interface EE300293 + IRSetup software</td> </tr> <tr> <td>RS485</td> <td>RS485 interface EE300294+ IRSetup software</td> </tr> <tr> <td>USB</td> <td>USB interface EE300295 + IRSetup software</td> </tr> <tr> <td>PROFI</td> <td>Profibus</td> </tr> <tr> <td>RELAY</td> <td>Relais interface EE300296 (2x optically isolated)</td> </tr> <tr> <td>LOG</td> <td>Event/Data Logging EE300297</td> </tr> </tbody> </table>	Table C	Options	NO	None	RS232	RS232 interface EE300293 + IRSetup software	RS485	RS485 interface EE300294+ IRSetup software	USB	USB interface EE300295 + IRSetup software	PROFI	Profibus	RELAY	Relais interface EE300296 (2x optically isolated)	LOG	Event/Data Logging EE300297																												
Table C	Options																																												
NO	None																																												
RS232	RS232 interface EE300293 + IRSetup software																																												
RS485	RS485 interface EE300294+ IRSetup software																																												
USB	USB interface EE300295 + IRSetup software																																												
PROFI	Profibus																																												
RELAY	Relais interface EE300296 (2x optically isolated)																																												
LOG	Event/Data Logging EE300297																																												
	<table border="1"> <thead> <tr> <th>Table D</th> <th>Calibration Certificate</th> </tr> </thead> <tbody> <tr> <td>NO</td> <td>None</td> </tr> <tr> <td>EC</td> <td>NIST traceable with data</td> </tr> </tbody> </table>	Table D	Calibration Certificate	NO	None	EC	NIST traceable with data																																						
Table D	Calibration Certificate																																												
NO	None																																												
EC	NIST traceable with data																																												
1158 - 814-25 - 3m - LOG - EC	Typical ordering code																																												

